

Maintenance-Free Bearing With Integrated Flange For Harsh Tillage

IL60-133/4H-3/4-16UNF

Maintenance-Free Bearing With Integrated Flange For Harsh Tillage
Disc Harrow

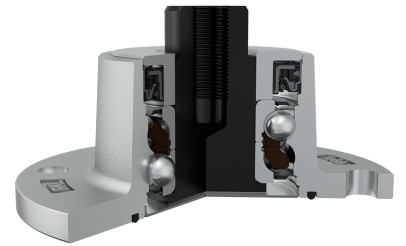
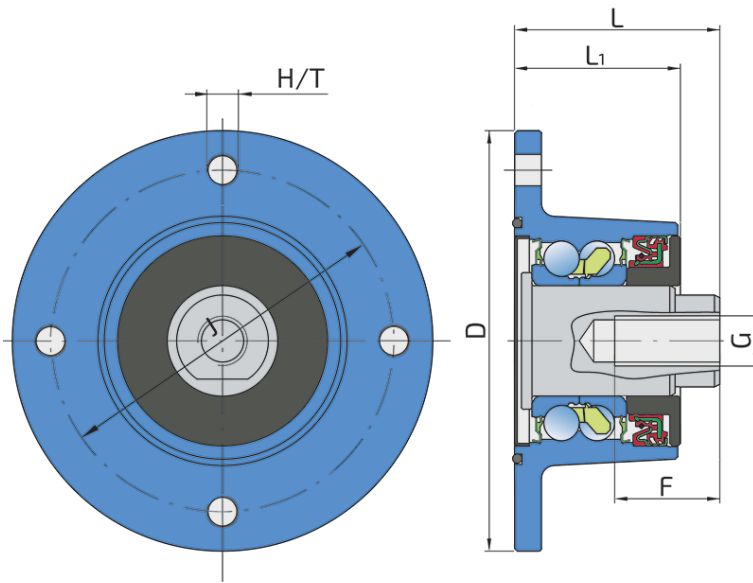

Technical Specification

J	Pitch circle diameter	133.35 mm
D	Outside diameter	160 mm
H/T	Hole/Thread	4x13.5 mm
d	Bore diameter	31 mm
C	D-shape hole cut out dimension	34.9 mm
G	Internal Thread	3/4"-16UNF mm
L	Total length	78 mm
L1	Total flange length	63 mm
F	Length of threaded part	40 mm
kg	Mass	4.1 kg
Cdyn	Dynamic load rating	66.35 kN
Co	Static load rating	56.5 kN
Pu	Fatigue load limit	2.37 kN

Sealing

O-RING+ SHEET METAL SHIELD+S SEAL / S SEAL+DIRTBLOCK SEAL+FORGED COVER PLATE

O-ring, Sheet metal shield and S seal on the base side and S seal, Dirtblock seal with Forged cover plate on the front side which is exposed to contaminants.

O-ring, Sheet metal shield and S seal together with attached disc eliminates the possibility of contamination from the base side.

Dirtblock seal is designed for hard working condition at unfriendly environment. Half metal - half rubber outside diameter provides reliable seal retention in the bore and improves sealing performance. Inside diameter is covered by rubber and improves sealing performance and easy installation. Forged cover plate is additional, strong protection of the Dirtblock seal against mechanical damage.

This sealing provides maximum protection against liquid or solid contaminants, which significantly extends bearing service life.

